

SilencerCo Hybrid

Field Manual

Thank you for choosing to add a SilencerCo suppressor to your collection. We love what we do and take great pride in the products we produce, and hope you will enjoy using this product as much as we enjoyed making it.

Each SilencerCo product carries our Lifetime Warranty. Should you have any questions after reading this manual, our best-in-class customer service team will be glad to assist you.

Again, thank you for joining SilencerCo as we work to **#FightTheNoise**.

Sincerely and Silently,



Joshua Waldron
SilencerCo Co-Founder & CEO

Note: If you have any questions whatsoever about whether you are performing the assembly, disassembly, or cleaning of the suppressor properly and in accordance with these instructions, you may contact SilencerCo customer service by phone at 801.417.5384 or via email at info@silencerco.com

For a list of available mounts and suppressors visit [SILENCERCO.COM/PRODUCTS/HYBRID](https://www.silencerco.com/products/hybrid)

© 2016 SilencerCo, LLC. All rights reserved. The contents of this publication may not be reproduced in any form or by any means in whole or in part without the prior written permission of the copyright owner.



The American Suppressor Association
is fighting to protect and expand your
suppressor rights. Join the fight today!

Become a member at
WWW.ASAMEMBER.COM

Contact us at:
INFO@AMERICANSUPPRESSORASSOCIATION.COM

Follow Us



/SILENCERCO



/SILENCERCO



@SILENCERCO



@SILENCERCO

HYBRID





 **Follow Us**

Join ASA Today

PROTECT YOUR RIGHTS | PROTECT YOUR HEARING





Register Your SilencerCo Product Online To Activate Your Lifetime Warranty

WWW.SILENCERCO.COM/PRODUCT-REGISTRATION



We at SilencerCo® hope that you enjoy the technological advancements offered by the Hybrid™ sound suppressor. To provide for your safety and the effective use of this suppressor, it is critical that the owner and any user of the suppressor read this entire manual and follow strictly the warnings and instructions within. This suppressor is intended to be used only by those who are well-versed in the safe operation of firearms.

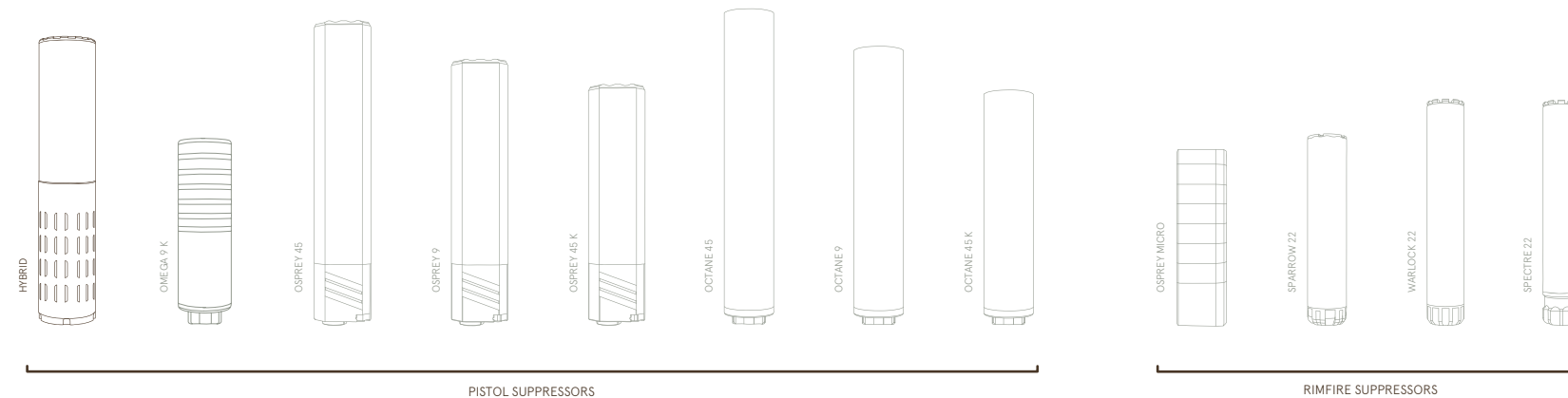

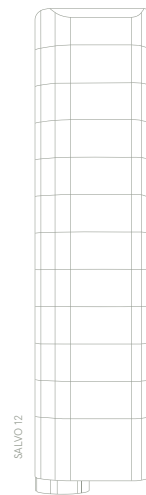

SALVO 12
SHOTGUN SUPPRESSOR



OMEGA



HARVESTER BIG BORE 338



HARVESTER 30



SAKER 762



SAKER 556



SAKER 556 K



SPECWAR 762



SPECWAR 556



SPECWAR 556 K

RIFLE SUPPRESSORS

MANUFACTURER'S DISCLAIMER

The manufacturer is not responsible for improper usage of this product. This product is potentially dangerous, and, as such, it is the user's responsibility to understand and implement its proper use. If you do not understand the instructions in this manual, please contact the manufacturer for further clarification at **801.417.5384**.

SONIC CRACK

The Hybrid is designed to suppress the initial muzzle blast and subsequent projectile de-corking pressure. The Hybrid does not contact or otherwise interact with the projectile, allowing the projectile to travel at its default speed. Because of this, a sonic crack is produced by the projectile as it breaks the sound barrier. Depending on the geography of the area, the sonic crack may vary in volume. This is solely a function of the projectile breaking the sound barrier and is not related to suppressor performance.

WARNING

Failure to follow installation and maintenance instructions detailed in this manual may result in serious personal injury and damage to the weapon. Firearm sound suppressors are user-attached firearm muzzle devices, and as such are subject to improper attachment issues unless the procedures outlined in this manual are followed precisely. Do not attempt to use this product unless you have specific training and experience in the use of firearms.

Before installing or removing the Hybrid sound suppressor from the host weapon, be sure that the weapon is unloaded and the action is opened so that it is visibly clear of any ammunition. If you are at all unsure as to the proper procedures to ensure that your firearm is unloaded, please consult your firearm user's manual/instructions and/or contact a properly licensed dealer or the manufacturer of your weapon.

Because suppressed firearms make less noise than unsuppressed firearms, it is easy to forget that they are still firearms and capable of causing bodily injury and property damage. It is of vital importance to remember that a suppressed firearm is just as dangerous as an unsuppressed firearm, and that the same safe handling requirements still apply.

When removing the Hybrid, use extreme caution as it may be hot to the touch after firing. Use gloves to avoid burns or other injuries.

Should a silencer require repair, the owner must contact SilencerCo and make arrangements to return the product. Customer must return damaged product with a legible copy of the approved ATF form and a legible written description of the problem, defect and/or malfunction.

Please include in written description the serial number of the product and the events leading up to the issue, including what ammunition has been used and any host weapons that have been used. If SilencerCo determines, at its sole and absolute discretion, that a returned suppressor is not covered under this warranty, for any reason, you may purchase a replacement product at 75% off the suggested retail price.

REPAIR POLICY

Should the silencer require repair or modification, the owner should contact SilencerCo either in writing or by telephone. Many problems can be handled without having to return the product. If it is determined that the product needs to be returned for repair or modification, contact SilencerCo customer service **801.417.5384** to obtain an RMA number. Do not return the suppressor to SilencerCo until you have contacted customer service, as an RMA code must be provided.

If repairs are required due to a defect in manufacturing or materials, there will be no charge for repairs. Subject to any restrictions set forth herein, SilencerCo agrees to replace and/or repair the Hybrid for an unlimited amount of time. This warranty covers repair, service and replacement of damaged product caused by normal use, free of charge, only if performed at a SilencerCo facility.

Check the fit between barrel and suppressor before firing! The thread mount must be fully shouldered on the barrel. There should be no visible gap between the barrel shoulder and the face of the suppressor thread mount. If there is any gap **DO NOT** fire the host with the suppressor attached. Poor accuracy and product damage may result if the suppressor is not fully shouldered.

Assembly and disassembly should never be performed while the suppressor is affixed in any manner to a host firearm. Always completely remove the Hybrid from the host firearm before assembly and/or disassembly is attempted.

Before performing maintenance, removing, or installing the suppressor, open the action, ensure firearm is unloaded, and be sure the chamber is empty. Failure to do so can result in property damage, injury, or death.

MADE IN THE USA

The Hybrid is the one silencer for any platform. Compatible with calibers ranging from 5.56mm to 9mm to .45-70 and .458 SOCOM and many in between, the Hybrid is both full auto and magnum-rated and can be used on pistols, rifles, and submachine guns. Boasting low-120 dB's on 300BLK and remaining hearing-safe with .45-70, the Hybrid offers an unparalleled pairing of versatility and performance—a combination you've come to expect from SilencerCo products. Reference the poster included in this box to see the full capabilities of the Hybrid.

The Hybrid is rated down to 16" barrels for .45-70 and .458 SOCOM. The Hybrid is rated down to 18" barrels for all magnum calibers up to .338.

Note: Suppressors must be free of obstructions such as mud, dirt, etc. Do NOT attempt to shoot through an obstructed suppressor.

The Hybrid was designed to be used "dry" and free of any ablative media, such as grease and water. If submerged in water, the user must allow a minimum 6 second drain time after exiting the water.

LIMITED LIFETIME WARRANTY

LIMITATIONS TO WARRANTY: THIS WARRANTY DOES NOT COVER DAMAGE TO THE SUPPRESSOR OR THE HOST FIREARM RESULTING FROM CARELESS OR IRRESPONSIBLE HANDLING, ADJUSTMENTS OR MODIFICATIONS TO ITS DESIGN, NEGLIGENCE OR OTHER ABUSE. SILENCERCO ASSUMES NO LIABILITY WHATSOEVER FOR UNSAFE USE OF THE SUPPRESSOR OR ILLEGAL USE BY ITS PURCHASER OR ANY OTHER PERSON THAT COMES IN CONTACT WITH THE PRODUCT AFTER PURCHASE. SILENCERCO ASSUMES NO RESPONSIBILITY FOR PHYSICAL INJURY OR PROPERTY

DAMAGE RESULTING FROM CARELESS OR IRRESPONSIBLE HANDLING AND/OR USE, OR BY ANY USE CONTRARY TO THE RECOMMENDATIONS, WARNINGS AND CAUTIONS GENERALLY LISTED IN THIS MANUAL. SILENCERCO DOES NOT COVER DAMAGE TO THE SUPPRESSOR OR THE HOST FIREARM RESULTING FROM IMPROPER HAND-LOADED OR RELOADED AMMUNITION OR DEFECTIVE AMMUNITION.

MAINTENANCE

The Hybrid typically requires limited maintenance. Mounts should periodically be cleaned with any standard gun cleaning solvent and a brush to remove any carbon or fouling. If necessary, run a cleaning brush through the bore to remove any light fouling of the suppressor.

Note: Do not run cleaning patches through the bore as the patches might become lodged in the suppressor and cause damage upon firing.

Caution: Always read the warning label on any cleaner or solvent, and remember that virtually all solvents are inherently dangerous and potentially toxic. Always use adequate ventilation and both skin and eye protection when using solvents.

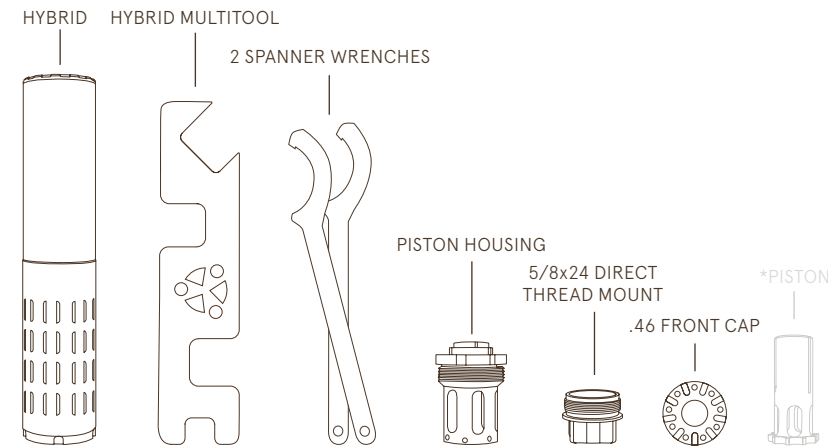

PRODUCT SPECS

INCLUDED

The Hybrid ships with the attached piston housing mount for use on pistols and subguns with a SilencerCo piston* (not included), a .46 flat front cap, and a 5/8x24 direct thread mount. All tools required for installation and removal are included. Additional accessories are available.

***Note: Piston not included. Must be purchased through dealer.**

MOUNTING OPTIONS

Whether you want to use the Hybrid on a pistol, subgun, or rifle, care should be taken to ensure that the suppressor is mounted securely to your firearm before firing. These instructions will help to prevent the problems and dangers that can arise from improper seating.

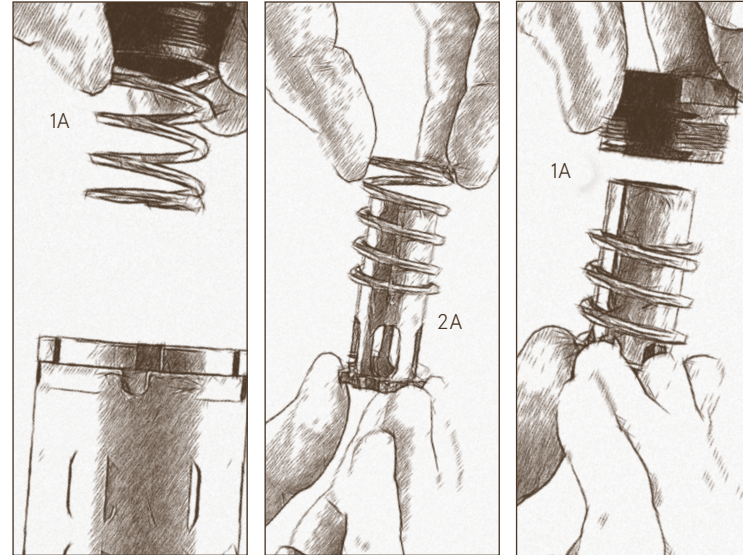

PISTON MOUNT

The Hybrid ships with the piston housing mount installed. You will need to install a piston (not included) into this housing in order for it to be compatible with a host.

Step 1: Unscrew the spring retainer/back cap (1A) from the rear of the Hybrid and remove the spring from the suppressor body; no tools are required.

Step 2: Place the spring over your piston (2A).

Step 3: Seat the non-knurled end of the piston into the spring retainer/back cap. Once the spring, piston, and retainer are properly seated together, place the assembly into the piston housing that is still in the back of the Hybrid.

Step 4: Hand tighten the back cap into the piston housing.

To remove the piston, reverse these steps.

MOUNTING ON A RIFLE

After confirming that your firearm is unloaded, place the direct thread mount over the end of the threads of the barrel. Taking care not to cross-thread, screw the suppressor onto the barrel until it is firmly secured and no additional barrel threading is visible. Hand tighten only.

To remove from host, reverse these instructions.

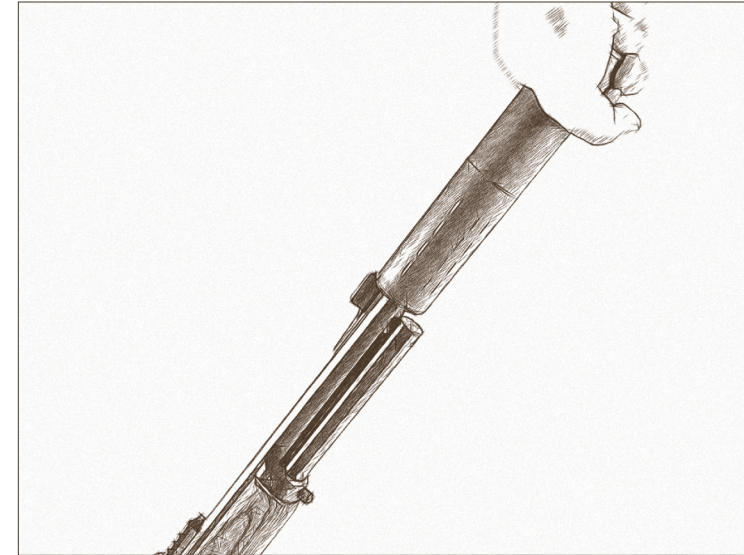

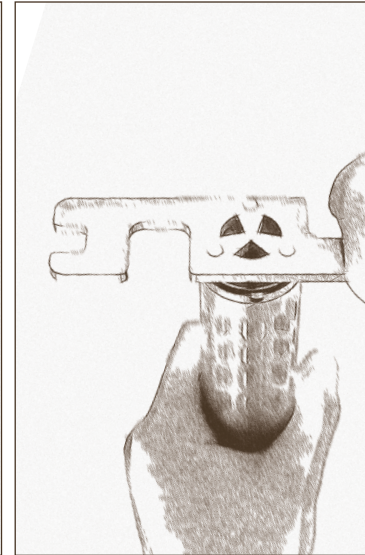
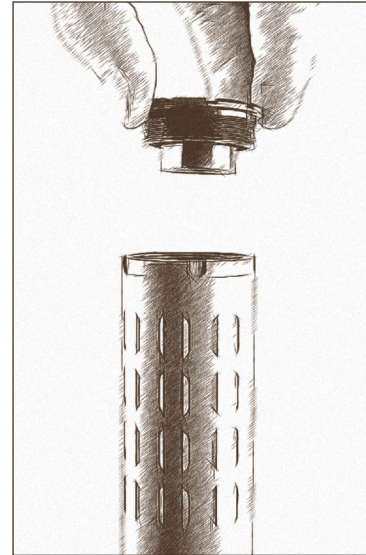

DIRECT THREAD MOUNT

Step 1: After removing the piston housing that ships installed on the Hybrid, screw the direct thread mount into the base of the Hybrid.

Step 2: Hold the Hybrid body with a firm grip and seat the three pegs of the included tool into the corresponding dimples in the face of the direct thread mount.

Step 3: Using a clockwise motion, securely tighten the mount into the back of the suppressor.

To remove, reverse these instructions.

MOUNTING *ON A PISTOL*

After confirming that your firearm is unloaded and securely seating the piston housing assembly into the Hybrid, thread the suppressor onto the threaded barrel of your pistol. Hand tighten only.

To remove from host, reverse these instructions.



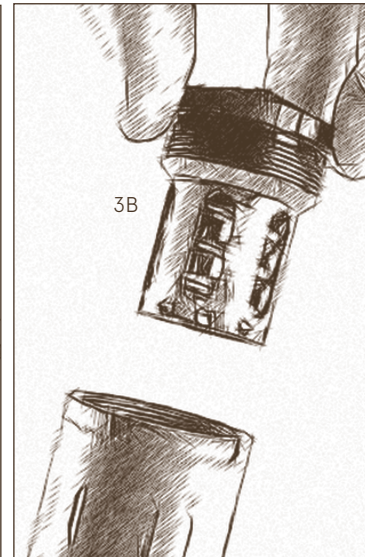
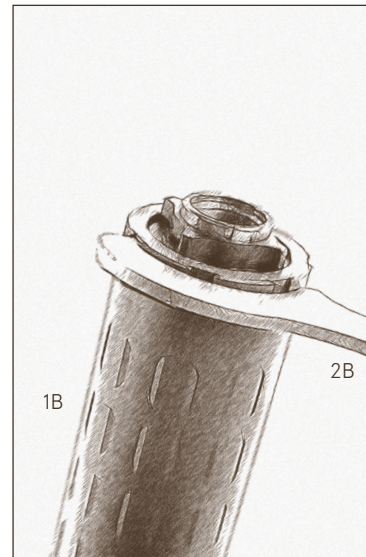

REMOVAL OF PISTON HOUSING

Should you want to use the Hybrid on a rifle or subgun instead of a pistol, you'll need to remove the piston housing.

Step 1: Hold the Hybrid (1B) in one hand while holding the spanner wrench (2B) in the other. Seat the teeth of the included spanner wrench into the notches of the piston housing (**note: NOT the notches on the Hybrid body**).

Step 2: Using a counterclockwise motion, loosen the piston housing mount (3B) and remove completely from the Hybrid body.

Tip: Should the piston housing prove particularly difficult to remove, seat the second provided spanner wrench (4B) into the notches of the body of the Hybrid in lieu of holding the suppressor in your hand as stated previously. Push handles of the two spanner wrenches toward each other to break the mount free. See image for example.

